

Engineering Your  
Competitive Edge



## SOLUTIONS FOR SMALL-PARTS MACHINING

***KENNA PRECISION™ O.D. and  
micro KENBORE™ I.D. Systems***

**KENNA PRECISION™ O.D. Systems**

Style J Series for Axial Turning  
 Toolholders .....6-7  
 Inserts .....8-9

Style K for Radial Turning  
 Toolholders .....10-11  
 Inserts .....12-14

**micro KENBORE™ I.D. Systems**

Toolholders .....16-17  
 Inserts .....18-19

**KENNA PRECISION Inserts and Holders**

**KENNA PRECISION J-Series Inserts and Holders for Axial Turning**  
 straight, copy, and groove turning

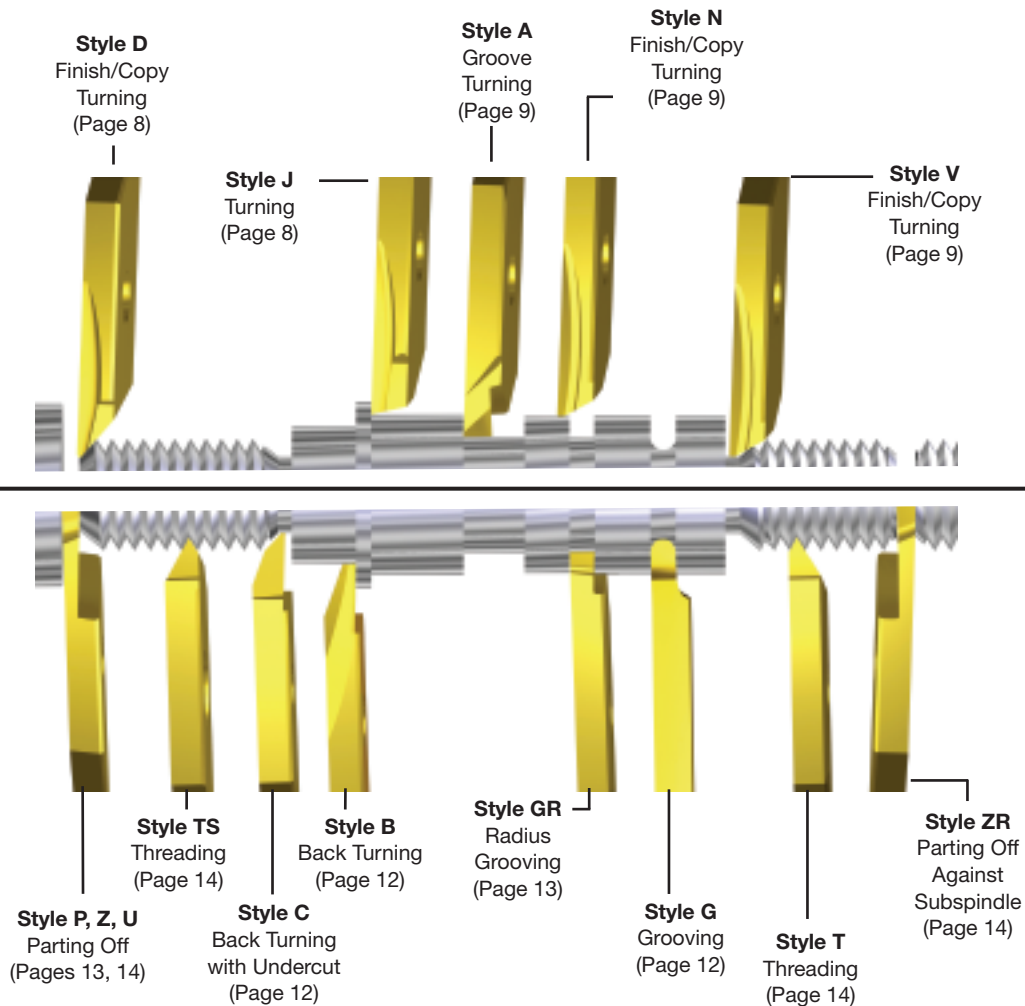

**KENNA PRECISION K-Series Inserts and Holders for Radial Turning**  
 parting off, grooving, threading, and back turning

**ACCELERATE... YOUR PRODUCTIVITY!**

# KENNA PRECISION™ O.D. and micro KENBORE™ I.D. Systems

**FAST, ACCURATE PRODUCTIVITY AT YOUR FINGERTIPS!**

## Cutting Data

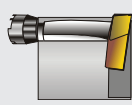
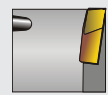
	Material	Hardness HB	Feed rate mm/rev	Speed m/min	
				K1025P	KC5020P
<b>KPK-J STYLE INSERTS</b> J style toolholder: identified by high side clearance  CLAMPING SCREW  CENTER-LOCK SCREW	Carbon Steel	150	0,10 - 0,22	160 - 270	200 - 350
		250	0,08 - 0,17	120 - 220	150 - 275
		350	0,07 - 0,14	70 - 140	100 - 200
	Alloy Steel	200	0,08 - 0,20	110 - 190	150 - 275
		300	0,07 - 0,16	70 - 140	100 - 200
		400	0,06 - 0,15	50 - 100	70 - 140
	Stainless Steel	150	0,08 - 0,20	110 - 190	150 - 275
		250	0,07 - 0,16	70 - 140	100 - 200
		350	0,06 - 0,15	50 - 100	70 - 140
	High-Temp Alloy	200	0,05 - 0,12	40 - 110	50 - 130
		300	0,05 - 0,12	25 - 90	30 - 110
		400	0,05 - 0,12	20 - 65	25 - 80
	Brass	<100	0,10 - 0,35	300 - 700	400 - 1000
		>100	0,08 - 0,28	250 - 500	300 - 700
	Copper	<100	0,10 - 0,35	250 - 500	300 - 700
		>100	0,08 - 0,28	175 - 350	250 - 500
	Aluminum	<100	0,10 - 0,20	300 - 700	400 - 1000
		>100	0,08 - 0,20	250 - 500	300 - 700

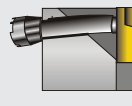
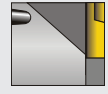
	Material	Hardness HB	Feed rate mm/rev	Speed m/min	
				K1025P	KC5020P
<b>KPK-K STYLE INSERTS</b> K style toolholder: identified by minimal side clearance  CLAMPING SCREW  CENTER-LOCK SCREW	Carbon Steel	150	0,07 - 0,15	130 - 230	160 - 270
		250	0,05 - 0,12	100 - 190	120 - 220
		350	0,04 - 0,10	60 - 120	70 - 140
	Alloy Steel	200	0,05 - 0,12	90 - 160	110 - 190
		300	0,04 - 0,10	60 - 120	70 - 140
		400	0,03 - 0,08	40 - 80	50 - 100
	Stainless Steel	150	0,05 - 0,12	90 - 160	110 - 190
		250	0,04 - 0,10	60 - 120	70 - 140
		350	0,03 - 0,08	40 - 80	50 - 100
	High-Temp Alloy	200	0,03 - 0,09	30 - 90	40 - 110
		300	0,03 - 0,09	20 - 75	25 - 90
		400	0,03 - 0,09	15 - 50	20 - 65
	Brass	<100	0,07 - 0,25	250 - 500	300 - 700
		>100	0,05 - 0,20	175 - 350	250 - 500
	Copper	<100	0,07 - 0,25	200 - 400	250 - 500
		>100	0,05 - 0,20	140 - 280	175 - 350
	Aluminum	<100	0,07 - 0,15	250 - 600	300 - 700
		>100	0,06 - 0,15	175 - 400	250 - 500

(Represents the recommended starting conditions. Optimize for your specific application.)

## Grade Selection

Grade	Coating	Composition and Application	ISO Class
K1025P		<b>composition:</b> A tough, micro-grained WC-Co grade with high hardness. <b>application:</b> Exceptional wear resistance combined with high edge strength for machining cast irons, austenitic stainless steels, non-ferrous alloys, and difficult-to-machine materials such as titanium and high-temperature superalloys. The micro-grained carbide allows the insert to have a very sharp, yet strong, edge.	M10 - M20 K15-K20 N10-N20 S10-S20
KC5020P		<b>composition:</b> A PVD TiN-coated straight WC-Co grade with very fine grain size. <b>application:</b> For general purpose machining of high-temperature alloys, stainless steels, and steels. The dense, smooth coating provides high wear resistance and reduces problems with built-up edge. Performs at higher speeds than the uncoated grade, K1025P.	P05-P15 M05-M20 S10-S20
KC5015P		<b>composition:</b> A PVD TiAlN coating over a deformation-resistant unalloyed, carbide substrate. <b>application:</b> For finishing to general-purpose machining of steels, stainless steels, cast irons, non-ferrous materials, superalloys, and hardened materials at higher speeds. The grade is particularly suitable where extreme heat is developed during machining.	P05-P15 M05-M20 K10-K20 S05-S20
K1025		<b>composition:</b> A fine-grained WC-Co grade with excellent toughness. <b>application:</b> Good wear resistance combined with high edge strength for machining steels, stainless steels, non-ferrous alloys, and difficult-to-machine materials such as titanium and high-temperature superalloys.	P25-P30 M25-M30 N25-N30 S25-S30
KC5025		<b>composition:</b> An advanced PVD TiAlN-coated grade with a tough, fine-grained, unalloyed carbide substrate. <b>application:</b> For general-purpose machining of steels, stainless steels, cast irons, non-ferrous materials, and high-temp alloys at higher speeds. The grade is particularly suitable where extreme heat is developed during machining.	P20-P30 M20-M30 K20-K30 N20-N30 S20-S30

## Corner Radius Options

<b>SHARP CORNER INSERTS</b>	<b>FULL RADIUS INSERTS</b>	<b>INSERTS WITH WIPERS</b>	<b>INSERTS WITH RADIUS AND WIPERS</b>	<b>CUSTOM-GROUND CORNERS</b>
For maximum cutting forces on axial turning applications, some inserts have sharp corners.	For light radial pressure, long tool life, and a smooth finish, selected inserts are offered with a full radius.	To produce superior finish on a narrow edge insert, a wiper is ground parallel to the centerline of the axis of the machine.	For longer tool life with superior finishes in axial turning applications, selected inserts are available with radius and a wiper.	For increased tool life, specifically ground corners are available upon request.

## KM Micro™ Toolholder Identification System

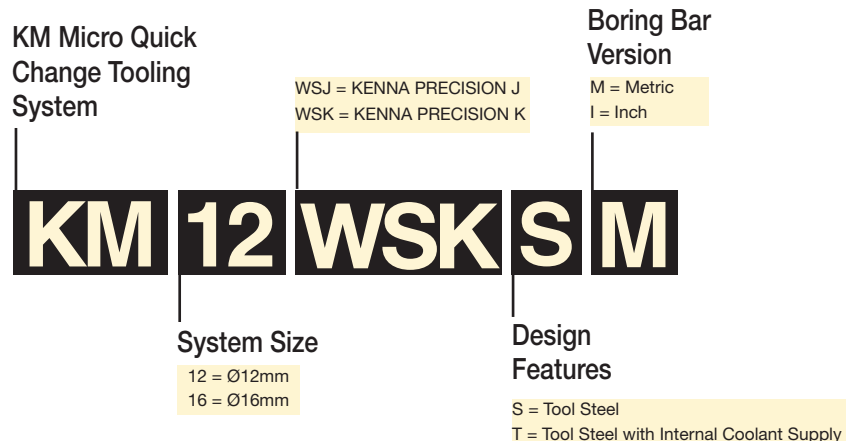

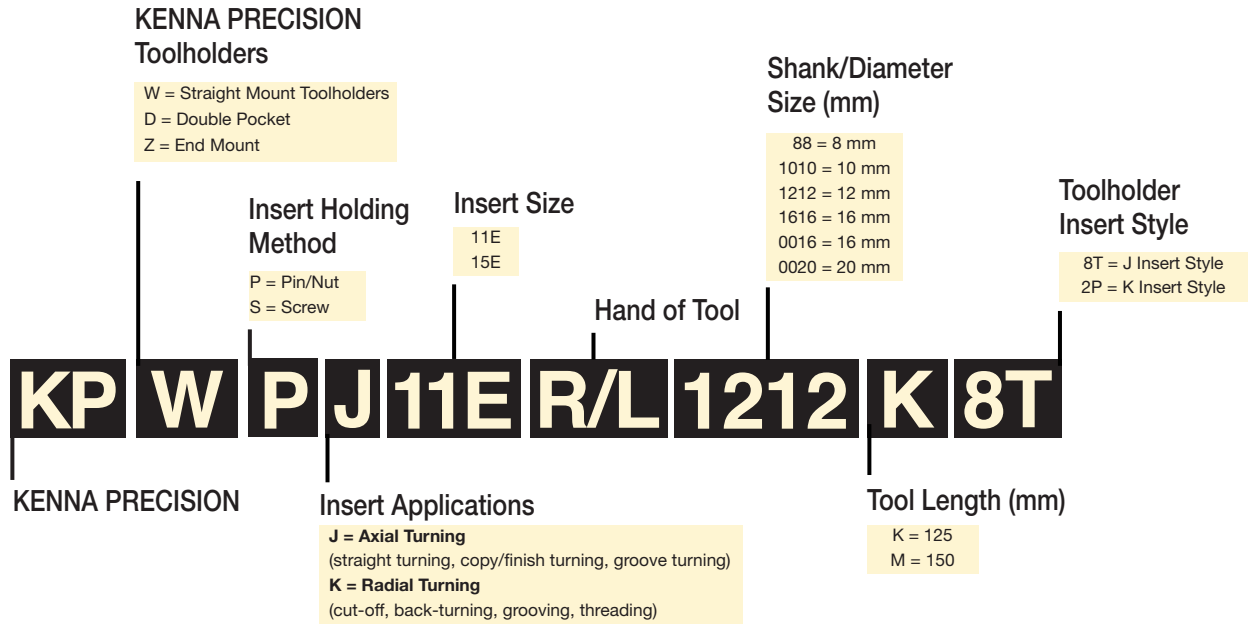

**Insert Identification System**

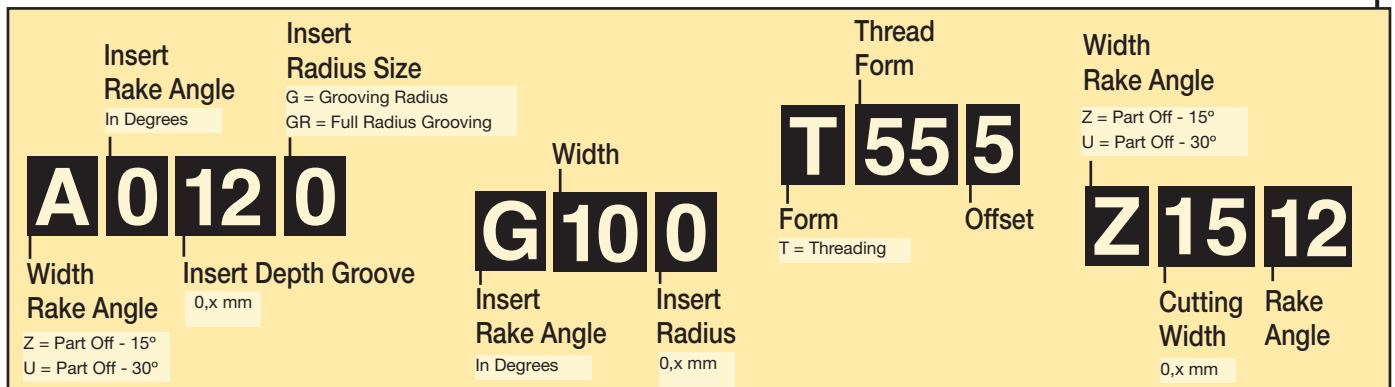
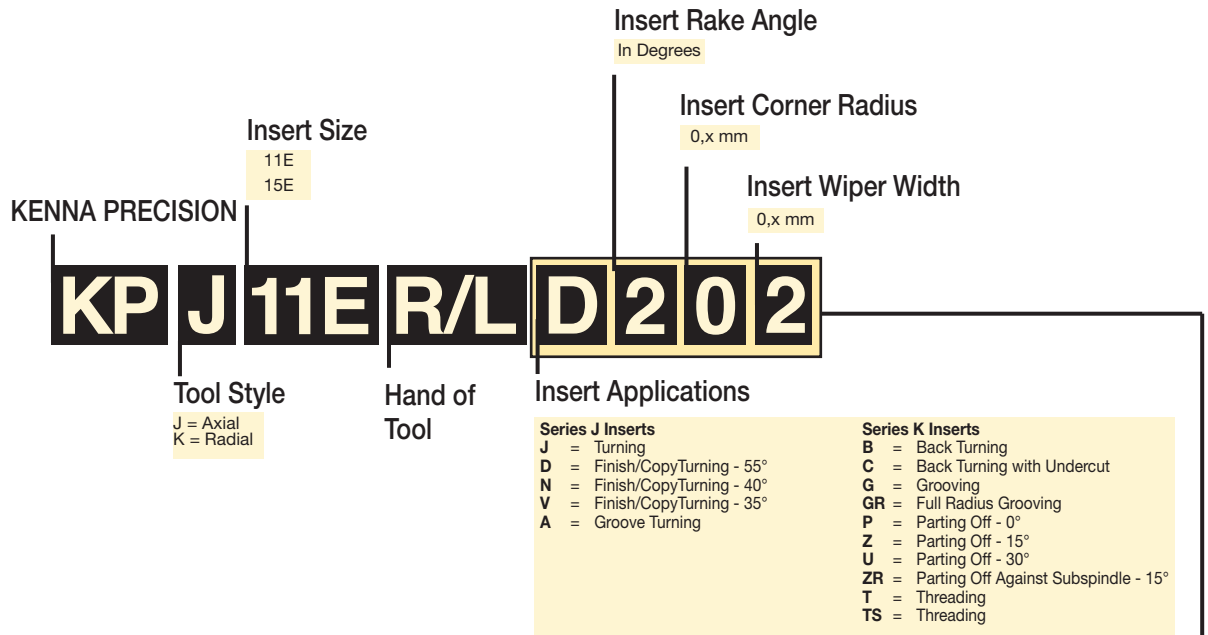

## Pin and Nut Insert Clamping System

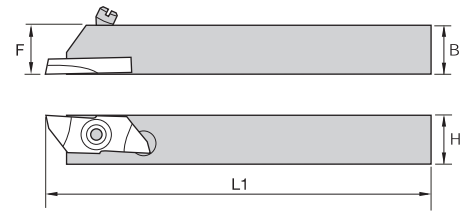
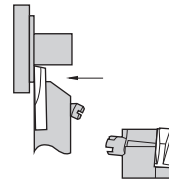

### ■ KPWPJ

order number	catalog number	B	H	F	L1	insert 1	bent screw and nut	drive bit
<b>Right hand</b>								
3123894	KPWPJ11ER88K8T	8	8	8	125	KPJ11ER..	KPPIN8	KP K3
3123892	KPWPJ11ER1010K8T	10	10	10	125	KPJ11ER..	KPPIN8	KP K3
3123898	KPWPJ15ER1010K8T	10	10	10	125	KPJ15ER..	KPPIN12	KP K3
3123901	KPWPJ15ER1212K8T	12	12	12	125	KPJ15ER..	KPPIN12	KP K3
3123902	KPWPJ15ER1616K8T	16	16	16	125	KPJ15ER..	KPPIN12	KP K3
<b>Left hand</b>								
3123891	KPWPJ11EL88K8T	8	8	8	125	KPJ11EL..	KPPIN8	KP K3
3123895	KPWPJ15EL1010K8T	10	10	10	125	KPJ15EL..	KPPIN8	KP K3
3123889	KPWPJ11EL1010K8T	10	10	10	125	KPJ11EL..	KPPIN12	KP K3
3123896	KPWPJ15EL1212K8T	12	12	12	125	KPJ15EL..	KPPIN12	KP K3
3123897	KPWPJ15EL1616K8T	16	16	16	125	KPJ15EL..	KPPIN12	KP K3

## KM Micro™ System

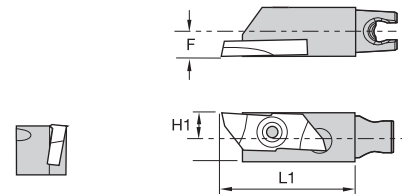

### ■ KM-WSJ

order number	catalog number	H1	L1	F	insert 1	insert screw	torx wrench
<b>Right hand</b>							
3522579	KM12WSJ15ER20	6	20	8	KPJ15EL...	KPM3X7	FT9
3522575	KM16WSJ15ER20	8	20	10	KPJ15ER...	KPM3X7	FT9
<b>Left hand</b>							
3522578	KM12WSJ15EL20	6	20	8	KPJ15ER...	KPM3X7	FT9
3522574	KM16WSJ15EL20	8	20	10	KPJ15EL...	KPM3X7	FT9

Available September 2007.

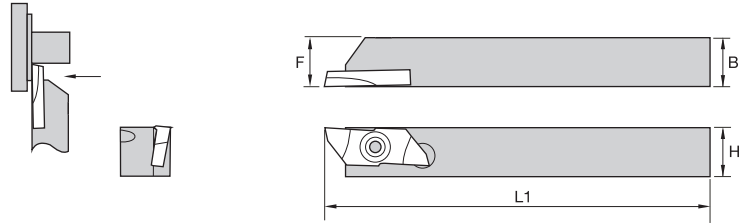

### ■ KPWSJ

order number	catalog number	B	H	F	L1	insert 1	insert screw	torx wrench
<b>Right hand</b>								
3123881	KPWSJ11ER88K8T	8	8	8	125	KPJ11ER..	KPM25X6	FT7
3123885	KPWSJ15ER1010K8T	10	10	10	125	KPJ11ER..	KPM3X7	FT9
3123887	KPWSJ15ER1212K8T	12	12	12	125	KPJ15ER..	KPM3X7	FT9
3123888	KPWSJ15ER1616K8T	16	16	16	125	KPJ15ER..	KPM3X7	FT9
<b>Left hand</b>								
3123880	KPWSJ11EL88K8T	8	8	8	125	KPJ11EL..	KPM25X6	FT7
3123882	KPWSJ15EL1010K8T	10	10	10	125	KPJ11EL..	KPM3X7	FT9
3123883	KPWSJ15EL1212K8T	12	12	12	125	KPJ15EL..	KPM3X7	FT9
3123884	KPWSJ15EL1616K8T	16	16	16	125	KPJ15EL..	KPM3X7	FT9

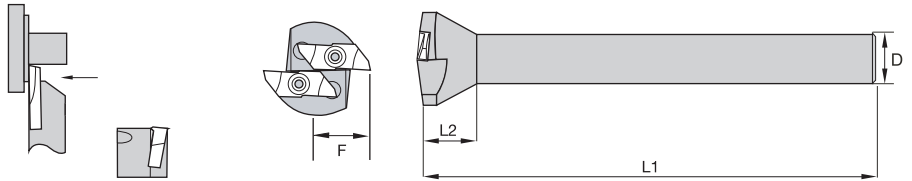

### ■ KPDSJ

order number	catalog number	D	F	L1	L2	insert 1	insert screw	torx wrench
<b>Right hand</b>								
3123855	KPDSJ15ER0016M8T	16	14	150	8	KPJ15ER..	KPM3X7	FT9
3123856	KPDSJ15ER0020M8T	20	14	150	5	KPJ15ER..	KPM3X7	FT9

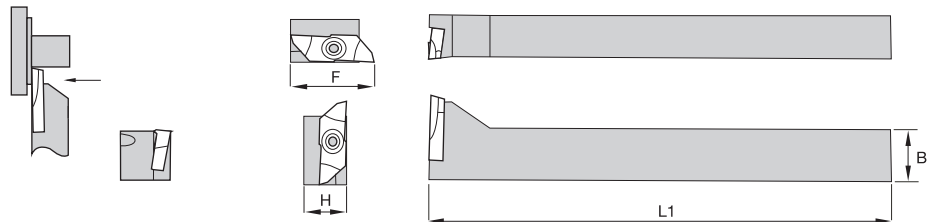

### ■ KPZSJ

order number	catalog number	B	H	F	L1	insert 1	insert screw	torx wrench
<b>Right hand</b>								
3123859	KPZSJ15ER1212K8T	12	12	20	125	KPJ15ER..	KPM3X7	FT9
3123860	KPZSJ15ER1616K8T	16	16	24	125	KPJ15ER..	KPM3X7	FT9

## Turning Inserts

### ■ KPJ-J

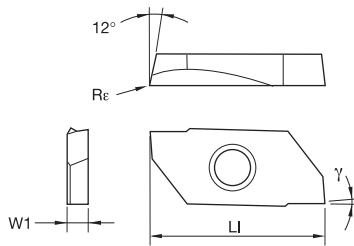

catalog number	Re (RR)	Re (RL)	$\gamma$	W1	LI	K1025P	KC5015P	KC5020P
<b>Right hand</b>								
KPJ11ERJ80	—	—	8.0	2,5	11,0			●
KPJ11ERJ82	0,2	—	8.0	2,5	11,0			●
KPJ11ERJ200	—	—	20.0	2,5	11,0			●
KPJ11ERJ202	0,2	—	20.0	2,5	11,0			●
KPJ15ERJ80	—	—	8.0	2,1	15,0			●
KPJ15ERJ81	0,1	—	8.0	2,1	15,0			●
KPJ15ERJ82	0,2	—	8.0	2,1	15,0			●
KPJ15ERJ200	—	—	20.0	2,1	15,0			●
KPJ15ERJ201	0,1	—	20.0	2,1	15,0			●
KPJ15ERJ202	0,2	—	20.0	2,1	15,0			●
<b>Left hand</b>								
KPJ11ELJ80	—	—	8.0	2,5	11,0			●
KPJ11ELJ82	—	0,2	8.0	2,5	11,0			●
KPJ11ELJ200	—	—	20.0	2,5	11,0			●
KPJ11ELJ202	—	0,2	20.0	2,5	11,0			●
KPJ15ELJ80	—	—	8.0	2,1	15,0			●
KPJ15ELJ81	0,1	—	8.0	2,1	15,0			●
KPJ15ELJ82	—	0,2	8.0	2,1	15,0			●
KPJ15ELJ200	—	—	20.0	2,1	15,0			●
KPJ15ELJ201	—	0,1	20.0	2,1	15,0			●
KPJ15ELJ202	—	0,2	20.0	2,1	15,0			●

## 55° Finish/Copy Turning Inserts

### ■ KPJ-D

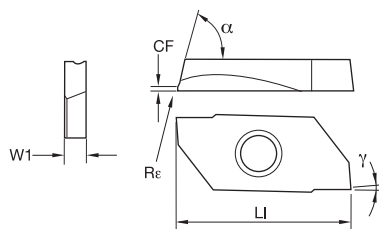

catalog number	CF	Re (RR)	Re (RL)	$\alpha$ L	$\alpha$ R	$\gamma$	W1	LI	K1025P	KC5015P	KC5020P
<b>Right hand</b>											
KPJ11ERD20	—	0,0	—	35	—	2	2,5	11,0			●
KPJ11ERD201	0,1	—	—	35	—	2	2,5	11,0			●
KPJ11ERD120	—	0,0	—	35	—	12	2,5	11,0			●
KPJ11ERD1201	0,1	—	—	35	—	12	2,5	11,0			●
KPJ15ERD20	—	0,0	—	35	—	2	2,1	15,0			●
KPJ15ERD202	0,2	—	—	35	—	2	2,1	15,0			●
KPJ15ERD120	—	0,0	—	35	—	12	2,1	15,0			●
KPJ15ERD1202	0,2	—	—	35	—	12	2,1	15,0			●
KPJ15ERD1213	0,3	0,2	—	35	—	12	2,1	15,0			●
<b>Left hand</b>											
KPJ11ELD20	—	—	0,0	—	35	2	2,5	11,0			●
KPJ11ELD201	0,1	—	—	—	35	2	2,5	11,0			●
KPJ11ELD120	—	—	0,0	—	35	12	2,5	11,0			●
KPJ11ELD1201	0,1	—	—	—	35	12	2,5	11,0			●
KPJ15ELD20	—	—	0,0	—	35	2	2,1	15,0			●
KPJ15ELD202	0,2	—	—	—	35	2	2,1	15,0			●
KPJ15ELD120	—	—	0,0	—	35	12	2,1	15,0			●
KPJ15ELD1202	0,2	—	—	—	35	12	2,1	15,0			●
KPJ15ELD1213	0,3	—	0,2	—	35	12	2,1	15,0			●

Right-hand insert shown; left-hand insert is mirror image.

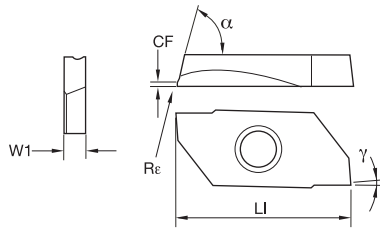
**KPJ-N**

catalog number	CF	R <sub>ε</sub> (RR)	R <sub>ε</sub> (RL)	αL	αR	γ	W1	LI	K1025P	KC5015P	KC5020P
<b>Right hand</b>											
KPJ15ERN202	0,2	—	—	50	—	2.0	2,1	15,0			●
KPJ15ERN213	0,3	0,1	—	50	—	2.0	2,1	15,0			●
KPJ15ERN1202	0,2	—	—	50	—	12.0	2,1	15,0			●
KPJ15ERN1213	0,3	0,1	—	50	—	12.0	2,1	15,0			●
<b>Left hand</b>											
KPJ15ELN202	0,2	—	—	—	50	2.0	2,1	15,0			●
KPJ15ELN213	0,3	—	0,1	—	50	2.0	2,1	15,0			●
KPJ15ELN1202	0,2	—	—	—	50	12.0	2,1	15,0			●
KPJ15ELN1213	0,3	—	0,1	—	50	12.0	2,1	15,0			●

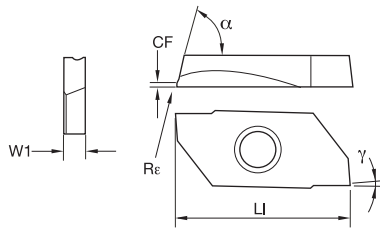
**35° Finish/Copy Turning Inserts**
**KPJ-V**

catalog number	CF	R <sub>ε</sub> (RR)	R <sub>ε</sub> (RL)	αL	αR	γ	W1	LI	K1025P	KC5015P	KC5020P
<b>Right hand</b>											
KPJ11ERV21	—	0,1	—	55	—	2.0	2,5	11,0			●
KPJ11ERV122	—	0,2	—	55	—	6.0	2,5	11,0			●
KPJ15ERV122	—	0,2	—	55	—	12.0	2,1	15,0			●
KPJ15ERV202	0,2	—	—	55	—	2.0	2,1	15,0			●
KPJ15ERV21	—	0,1	—	55	—	2.0	2,1	15,0			●
<b>Left hand</b>											
KPJ11ELV21	—	—	0,1	—	55	2.0	2,5	11,0			●
KPJ11ELV122	—	—	0,2	—	55	6.0	2,5	11,0			●
KPJ15ELV122	—	—	0,2	—	55	12.0	2,1	15,0			●
KPJ15ELV202	0,2	—	—	—	55	2.0	2,1	15,0			●
KPJ15ELV21	—	—	0,1	—	55	2.0	2,1	15,0			●

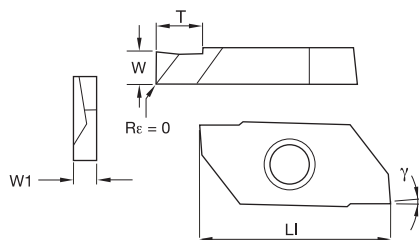
**Groove Turning Inserts**
**KPJ-A**

catalog number	W	T	γ	W1	LI	K1025P	KC5015P	KC5020P
<b>Right hand</b>								
KPJ11ERA00	1,3	2,0	12.0	2,5	11,0			●
KPJ11ERA120	1,3	2,0	—	2,5	11,0			●
KPJ15ERA120	1,5	2,3	12.0	2,1	15,0			●
KPJ15ERA12160	1,0	1,6	12.0	2,1	15,0			●
KPJ15ERA00	1,5	2,3	—	2,1	15,0			●
KPJ15ERA0080	0,5	0,8	—	2,1	15,0			●
KPJ15ERA0120	0,8	1,2	—	2,1	15,0			●
KPJ15ERA0160	1,0	1,6	—	2,1	15,0			●
<b>Left hand</b>								
KPJ11ELA120	1,3	2,0	12.0	2,5	11,0			●
KPJ11ELA00	1,3	2,0	—	2,5	11,0			●
KPJ15ELA120	1,5	2,3	12.0	2,1	15,0			●
KPJ15ELA12160	1,0	1,6	12.0	2,1	15,0			●
KPJ15ELA00	1,5	2,3	—	2,1	15,0			●
KPJ15ELA0080	0,5	0,8	—	2,1	15,0			●
KPJ15ELA0120	0,8	1,2	—	2,1	15,0			●
KPJ15ELA0160	1,0	1,6	—	2,1	15,0			●

Right-hand insert shown; left-hand insert is mirror image.

## Pin and Nut Insert Clamping System

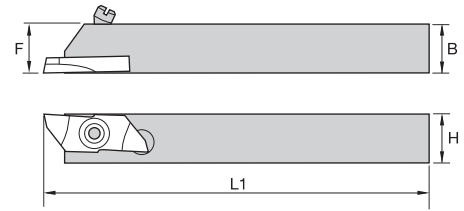
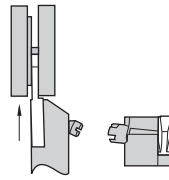

### ■ KPWPK

order number	catalog number	B	H	F	L1	insert 1	bent screw and nut	drive bit
<b>Right hand</b>								
3123911	KPWPK11ER88K2P	8	8	8	125	KPK11ER..	KPPIN8	KP K3
3123915	KPWPK15ER1010K2P	10	10	10	125	KPK15ER..	KPPIN8	KP K3
3123909	KPWPK11ER1010K2P	10	10	10	125	KPK11ER..	KPPIN12	KP K3
3123918	KPWPK15ER1212K2P	12	12	12	125	KPK15ER..	KPPIN12	KP K3
3123919	KPWPK15ER1616K2P	16	16	16	125	KPK15ER..	KPPIN12	KP K3
<b>Left hand</b>								
3123908	KPWPK11EL88K2P	8	8	8	125	KPK11EL..	KPPIN8	KP K3
3123912	KPWPK15EL1010K2P	10	10	10	125	KPK15EL..	KPPIN8	KP K3
3123906	KPWPK11EL1010K2P	10	10	10	125	KPK11EL..	KPPIN12	KP K3
3123913	KPWPK15EL1212K2P	12	12	12	125	KPK15EL..	KPPIN12	KP K3
3123914	KPWPK15EL1616K2P	16	16	16	125	KPK15EL..	KPPIN12	KP K3

## KM Micro™ System

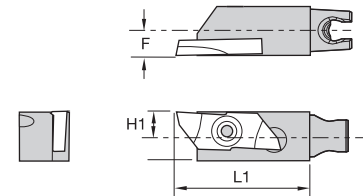

### ■ KM-WSK

order number	catalog number	H1	L1	F	insert 1	insert screw	torx wrench
<b>Right hand</b>							
3522581	KM12WSK15ER20	6	20	8	KPK15EL...	KPM3X7	FT9
3522577	KM16WSK15ER20	8	20	10	KPK15ER...	KPM3X7	FT9
<b>Left hand</b>							
3522580	KM12WSK15EL20	6	20	8	KPK15ER...	KPM3X7	FT9
3522576	KM16WSK15EL20	8	20	10	KPK15EL...	KPM3X7	FT9

Available September 2007.

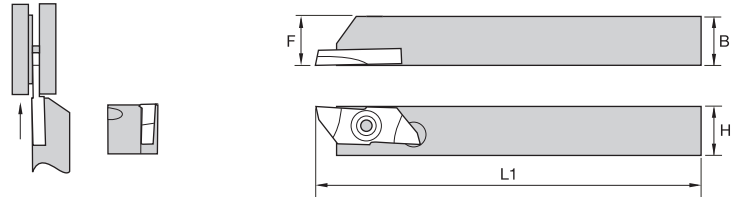

### ■ KPWSK

order number	catalog number	B	H	F	L1	insert 1	insert screw	torx wrench
<b>Right hand</b>								
3125679	KPWSK11ER88K2P	8	8	8	125	KPK11ER..	KPM25X6	FT7
3125684	KPWSK15ER1010K2P	10	10	10	125	KPK15ER..	KPM3X7	FT9
3125686	KPWSK15ER1212K2P	12	12	12	125	KPK15ER..	KPM3X7	FT9
3125687	KPWSK15ER1616K2P	16	16	16	125	KPK15ER..	KPM3X7	FT9
<b>Left hand</b>								
3125678	KPWSK11EL88K2P	8	8	8	125	KPK11EL..	KPM25X6	FT7
3125680	KPWSK15EL1010K2P	10	10	10	125	KPK15EL..	KPM3X7	FT9
3125682	KPWSK15EL1212K2P	12	12	12	125	KPK15EL..	KPM3X7	FT9
3125683	KPWSK15EL1616K2P	16	16	16	125	KPK15EL..	KPM3X7	FT9

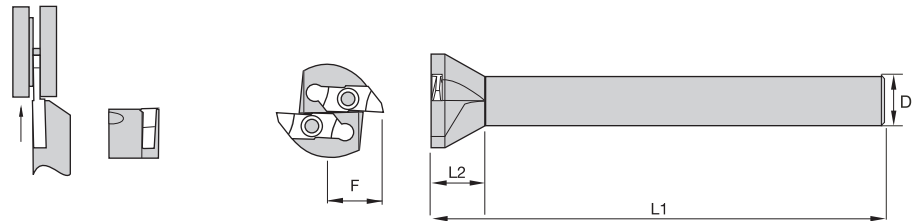

### ■ KPDSK

order number	catalog number	D	F	L1	L2	insert 1	insert screw	torx wrench
<b>Right hand</b>								
3123857	KPDSK15ER0016M2P	16	14	150	8	KPK15ER..	KPM3X7	FT9
3123858	KPDSK15ER0020M2P	20	14	150	5	KPK15ER..	KPM3X7	FT9

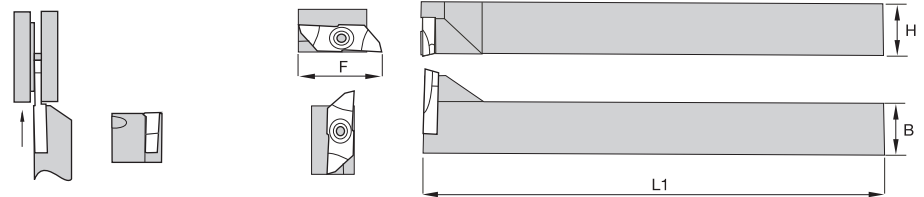

### ■ KPZSK

order number	catalog number	B	H	F	L1	insert 1	insert screw	torx wrench
<b>Right hand</b>								
3123861	KPZSK15ER1212K2P	12	12	20	125	KPK15ER..	KPM3X7	FT9
3123862	KPZSK15ER1616K2P	16	16	24	125	KPK15ER..	KPM3X7	FT9

## Back Turning Inserts

### ■ KPK-B

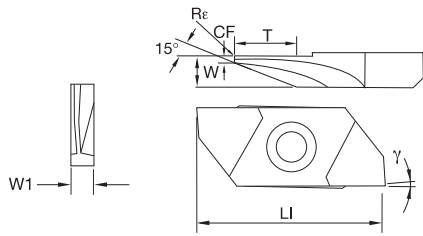

catalog number	W	CF	T	Re (RR)	Re (RL)	$\gamma$	W1	LI	K1025P	KC5015P	KC5020P
<b>Right hand</b>											
KPK11ERB1220	1,0	0,4	2,0	—	—	12,0	2,5	11,0			●
KPK11ERB1230	1,5	0,6	3,5	—	—	12,0	2,5	11,0			●
KPK15ERB1220	1,3	0,5	2,5	—	—	12,0	2,1	15,0			●
KPK15ERB1240	1,9	0,7	4,0	—	—	12,0	2,1	15,0			●
KPK15ERB1241	1,9	0,7	4,0	—	0,1	12,0	2,1	15,0			●
KPK15ERB1242	1,9	0,7	4,0	—	0,2	12,0	2,1	15,0			●
<b>Left hand</b>											
KPK11ELB1220	1,0	0,4	2,0	—	—	12,0	2,5	11,0			●
KPK11ELB1230	1,5	0,6	3,5	—	—	12,0	2,5	11,0			●
KPK15ELB1220	1,3	0,5	2,5	—	—	12,0	2,1	15,0			●
KPK15ELB1240	1,9	0,7	4,0	—	—	12,0	2,1	15,0			●
KPK15ELB1241	1,9	0,7	4,0	0,1	—	12,0	2,1	15,0			●
KPK15ELB1242	1,9	0,7	4,0	0,2	—	12,0	2,1	15,0			●

## Back Turning Inserts with Undercut

### ■ KPK-C

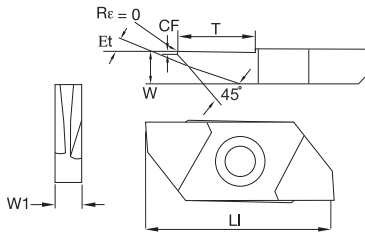

catalog number	W	CF	T	$\alpha L$	$\alpha R$	Et	W1	LI	K1025P	KC5015P	KC5020P
<b>Right hand</b>											
KPK11ERC010	1,0	0,2	1,3	—	15,0	30,0	3	11			●
KPK15ERC030	1,9	0,2	3,0	—	25,0	20,0	2	15			●
<b>Left hand</b>											
KPK11ELC010	1,0	0,2	1,3	15	—	30,0	3	11			●
KPK15ELC030	1,9	0,2	3,0	25	—	20,0	2	15			●

## Grooving Inserts

### ■ KPK-G

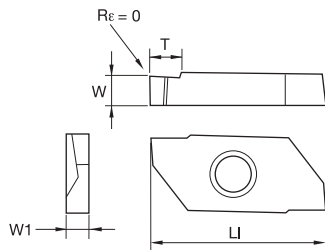

catalog number	W	T	W1	LI	K1025P	KC5015P	KC5020P
<b>Right hand</b>							
KPK11ERG05	0,5	1,0	2,5	11,0			●
KPK11ERG08	0,8	1,6	2,5	11,0			●
KPK11ERG10	1,0	2,0	2,5	11,0			●
KPK15ERG01	0,1	0,2	2,1	15,0			●
KPK15ERG025	0,3	0,5	2,1	15,0			●
KPK15ERG05	0,5	1,0	2,1	15,0			●
KPK15ERG08	0,8	1,6	2,1	15,0			●
KPK15ERG10	1,0	2,0	2,1	15,0			●
KPK15ERG15	1,5	3,0	2,1	15,0			●
<b>Left hand</b>							
KPK15ERG205	2,1	4,1	2,1	15,0			●
<b>Right hand</b>							
KPK11ELG05	0,5	1,0	2,5	11,0			●
KPK11ELG08	0,8	1,6	2,5	11,0			●
KPK11ELG10	1,0	2,0	2,5	11,0			●
KPK15ELG05	0,5	1,0	2,1	15,0			●
KPK15ELG08	0,8	1,6	2,1	15,0			●
KPK15ELG10	1,0	2,0	2,1	15,0			●
KPK15ELG15	1,5	3,0	2,1	15,0			●
KPK15ELG205	2,1	4,1	2,1	15,0			●

Right-hand insert shown; left-hand insert is mirror image.

### ■ KPK-GR

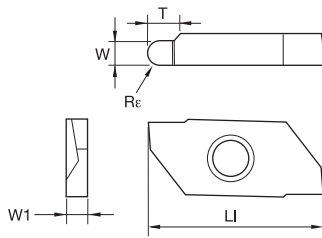

catalog number	W	T	Re (RC)	W1	LI	K1025P	KC5015P	KC5020P
<b>Right hand</b>								
KPK15ERGR025	0,5	0,4	0,3	2,1	15,0			●
KPK15ERGR05	1,0	0,8	0,5	2,1	15,0			●
KPK15ERGR075	1,5	1,2	0,8	2,1	15,0			●
KPK15ERGR10	2,0	1,5	1,0	2,1	15,0			●

### 0° Cut-Off Inserts

### ■ KPK-P

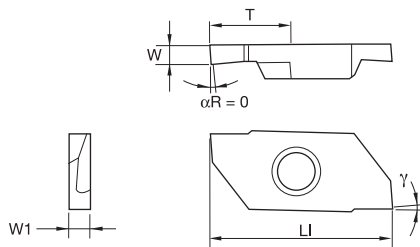

catalog number	W	T	$\gamma$	W1	LI	K1025P	KC5015P	KC5020P
<b>Right hand</b>								
KPK11ERP0812	0,8	4	12,0	2,5	11,0			●
KPK11ERP1012	1,0	5	12,0	2,5	11,0			●
KPK11ERP1512	1,5	6	12,0	2,5	11,0			●
KPK15ERP1012	1,0	5	12,0	2,1	15,0			●
KPK15ERP1212	1,2	6	12,0	2,1	15,0			●
KPK15ERP1512	1,5	6	12,0	2,1	15,0			●
KPK15ERP2012	2,0	6	12,0	2,1	15,0			●
<b>Left hand</b>								
KPK11ELP0812	0,8	4	12,0	2,5	11,0			●
KPK11ELP1012	1,0	5	12,0	2,5	11,0			●
KPK11ELP1512	1,5	6	12,0	2,5	11,0			●
KPK15ELP0712	0,7	3	12,0	2,1	15,0			●
KPK15ELP1012	1,0	5	12,0	2,1	15,0			●
KPK15ELP1212	1,2	6	12,0	2,1	15,0			●
KPK15ELP1512	1,5	6	12,0	2,1	15,0			●
KPK15ELP2012	2,0	6	12,0	2,1	15,0			●

### 15° Cut-Off Inserts

### ■ KPK-Z

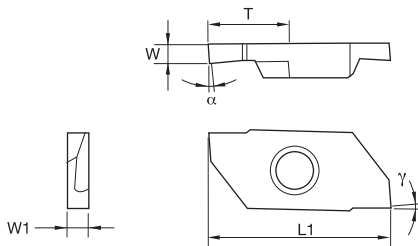

catalog number	W	T	$\alpha L$	$\alpha R$	$\gamma$	W1	LI	K1025P	KC5015P	KC5020P
<b>Right hand</b>										
KPK11ERZ1012	1,0	4,5	—	15	12	2,5	11,0			●
KPK11ERZ1512	1,5	5,5	—	15	12	2,5	11,0			●
KPK11ERZ100	1,0	4,5	—	15	—	2,5	11,0			●
KPK11ERZ150	1,5	5,5	—	15	—	2,5	11,0			●
KPK15ERZ0712	0,7	2,5	—	15	12	2,1	15,0			●
KPK15ERZ1012	1,0	5,0	—	15	12	2,1	15,0			●
KPK15ERZ1512	1,5	6,0	—	15	12	2,1	15,0			●
KPK15ERZ2012	2,0	6,0	—	15	12	2,1	15,0			●
KPK15ERZ070	0,7	2,5	—	15	—	2,1	15,0			●
KPK15ERZ100	1,0	5,0	—	15	—	2,1	15,0			●
KPK15ERZ150	1,5	6,0	—	15	—	2,1	15,0			●
KPK15ERZ200	2,0	6,0	—	15	—	2,1	15,0			●
<b>Left hand</b>										
KPK11ELZ1012	1,0	4,5	15	—	12	2,5	11,0			●
KPK11ELZ1512	1,5	5,5	15	—	12	2,5	11,0			●
KPK11ELZ100	1,0	4,5	15	—	—	2,5	11,0			●
KPK11ELZ150	1,5	5,5	15	—	—	2,5	11,0			●
KPK15ELZ0712	0,7	2,5	15	—	12	2,1	15,0			●
KPK15ELZ1012	1,0	5,0	15	—	12	2,1	15,0			●
KPK15ELZ1512	1,5	6,0	15	—	12	2,1	15,0			●
KPK15ELZ2012	2,0	6,0	15	—	12	2,1	15,0			●
KPK15ELZ070	0,7	2,5	15	—	—	2,1	15,0			●
KPK15ELZ100	1,0	5,0	15	—	—	2,1	15,0			●
KPK15ELZ150	1,5	6,0	15	—	—	2,1	15,0			●
KPK15ELZ200	2,0	6,0	15	—	—	2,1	15,0			●

Right-hand insert shown; left-hand insert is mirror image.

## 30° Cut-Off Inserts

### ■ KPK-U

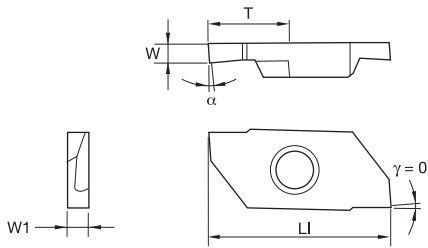

catalog number	W	T	αL	αR	W1	LI	K1025P	KC5015P	KC5020P
<b>Right hand</b>									
KPK11ERU100	1,0	4,0	—	30	2,5	11,0			●
KPK15ERU100	1,0	4,5	—	30	2,1	15,0			●
KPK15ERU150	1,5	6,0	—	30	2,1	15,0			●
<b>Left hand</b>									
KPK11ELU100	1,0	4,0	30	—	2,5	11,0			●
KPK15ELU100	1,0	4,5	30	—	2,1	15,0			●
KPK15ELU150	1,5	6,0	30	—	2,1	15,0			●

## 15° Cut-Off Inserts Against Subspindle

### ■ KPK-ZR

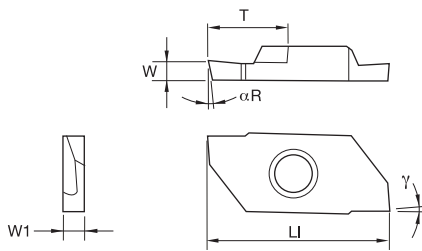

catalog number	W	T	αR	γ	W1	LI	K1025P	KC5015P	KC5020P
<b>Left hand</b>									
KPK11ELZR100	1,0	4,5	15	—	2,5	11,0			●
KPK11ELZR150	1,5	5,5	15	—	2,5	11,0			●
KPK11ELZR1012	1,0	4,5	15	12	2,5	11,0			●
KPK11ELZR1512	1,5	5,5	15	12	2,5	11,0			●
KPK15ELZR100	1,0	5,0	15	—	2,1	15,0			●
KPK15ELZR150	1,5	6,0	15	—	2,1	15,0			●
KPK15ELZR200	2,0	6,0	15	—	2,1	15,0			●
KPK15ELZR1012	1,0	5,0	15	12	2,1	15,0			●
KPK15ELZR1512	1,5	6,0	15	12	2,1	15,0			●
KPK15ELZR2012	2,0	6,0	15	12	2,1	15,0			●

## Threading Inserts

### ■ KPK-T & TS

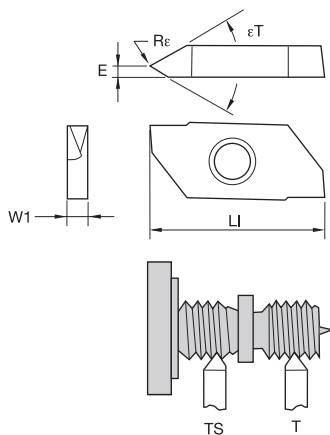

catalog number	E	Re (RC)	εT	W1	LI	K1025P	KC5015P	KC5020P	
<b>Right hand</b>									
KPK11ERT555	2,0	0	55	3	11,0			●	
KPK11ERT605	2,0	0	60	3	11,0			●	
KPK15ERT555	1,6	0	55	2	15,0			●	
KPK15ERT605	1,6	0	60	2	15,0			●	
KPK15ERT608	1,3	0	60	2	15,0			●	
KPK15ERTS6016	0,5	0	60	2	15,0			●	
<b>Left hand</b>									
KPK11ELT555	2,0	0	55	3	11,0			●	
KPK11ELT605	2,0	0	60	3	11,0			●	
KPK15ELT555	1,6	0	55	2	15,0			●	
KPK15ELT605	1,6	0	60	2	15,0			●	
KPK15ELT608	1,3	0	60	2	15,0			●	
KPK15ELTS6016	0,5	0	60	2	15,0			●	

NOTE:

Insert	max (TPI)	Pitch
T60 / TS60 / T55	26	1,0
T605	80	0,25
T608	48	0,5

Right-hand insert shown; left-hand insert is mirror image.

# micro KENBORE Tooling System

**micro KENBORE tools are versatile.**

Inserts are designed for use in steels, stainless steels, non-ferrous metals, superalloys, titanium, and hard materials.

**Inserts are tightly secured in the toolholder.**

Clamping screw securely holds the inserts in the seat pocket, even during pull-boring operations. Fixed-limit stop ensures precise and repeatable positioning of the cutting edge.

**Clamping screw position is adjustable.**

All tool bodies have three clamping surfaces for positioning the clamping screw to ensure the best results in any machine configuration. This feature, along with insert indexing, enables flexibility in machine setup.

**Cutting inserts are indexable.**

Use of V-slots positioned every 90° and the limit stop bolt enable indexing of the cutting edge in 90° increments.

**Toolholder and insert design enables internal coolant supply.**

Internal coolant can be used with all tool bodies. Cutting inserts have special slots which direct cooling lubricant to the cutting edge.



micro KENBORE boring inserts (MKTB) and profiling inserts (MKTP)

	D <sub>min</sub> (mm)	Cutting Depth ap (mm)	Feed rate (mm/r)
<b>Steel</b> v <sub>c</sub> = 45 – 120 m/min	1,58	0,02 - 0,10	0,04 - 0,01
	2,38	0,02 - 0,13	0,05 - 0,01
	3,17	0,02 - 0,18	0,06 - 0,02
	3,96	0,02 - 0,20	0,07 - 0,02
<b>Stainless Steel</b> v <sub>c</sub> = 45 – 90 m/min	1,58	0,02 - 0,10	0,03 - 0,01
	2,38	0,02 - 0,13	0,04 - 0,01
	3,17	0,02 - 0,18	0,06 - 0,02
	3,96	0,02 - 0,20	0,07 - 0,02
<b>Non-Ferrous Metals</b> v <sub>c</sub> = 75 – 600 m/min	1,58	0,02 - 0,30	0,05 - 0,01
	2,38	0,02 - 0,38	0,06 - 0,01
	3,17	0,02 - 0,45	0,08 - 0,02
	3,96	0,02 - 0,55	0,09 - 0,02
<b>Superalloys and Titanium</b> v <sub>c</sub> = 25 – 50 m/min	1,58	0,02 - 0,07	0,03 - 0,01
	2,38	0,02 - 0,07	0,04 - 0,01
	3,17	0,02 - 0,12	0,06 - 0,02
	3,96	0,02 - 0,20	0,06 - 0,02

Toolholder Identification System

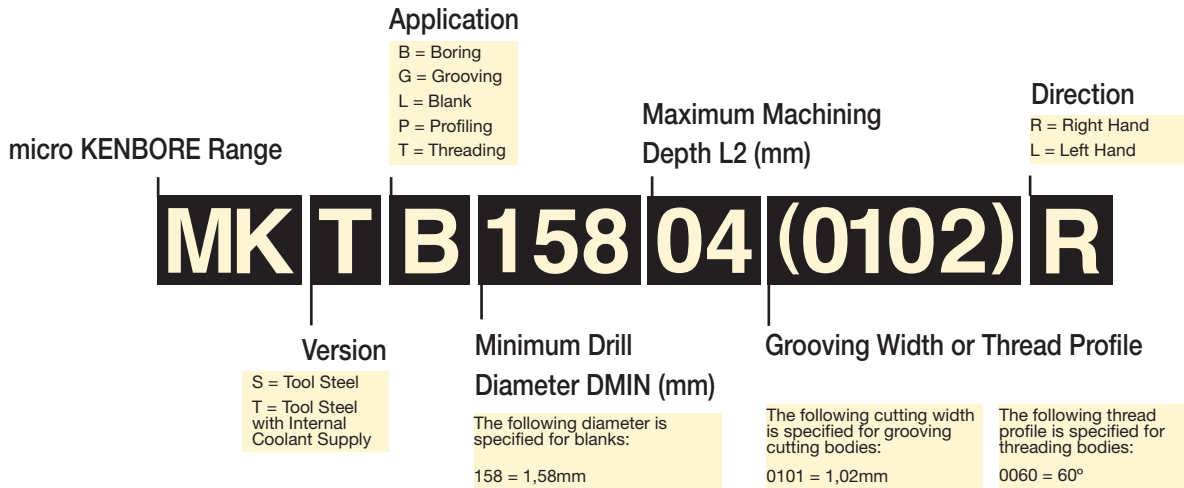

Insert Identification System

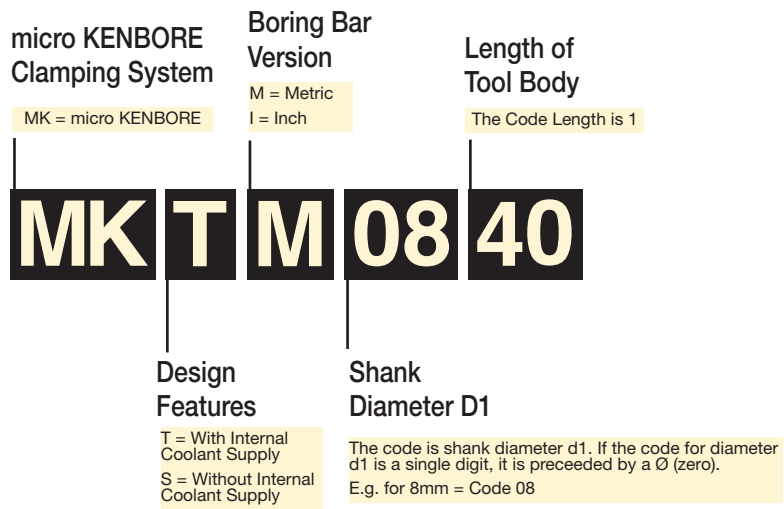

KM Micro™ Toolholder Identification System

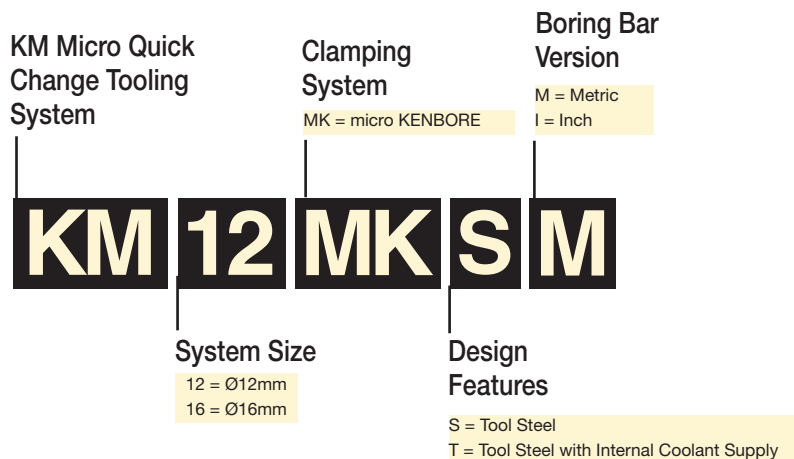

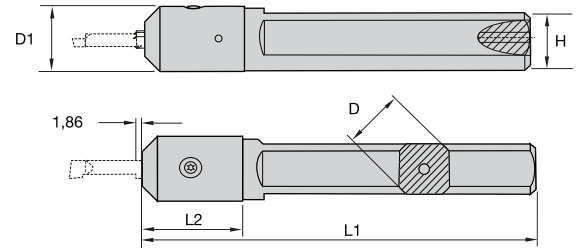

### ■ MKTM

order number	catalog number	D1	D	L2	L1	H	oval point socket set screw	hex wrench
2225941	MKTM08100	4,0	8,0	82,6	101,6	7,2	MSM46	170.002
2226023	MKTM10100	4,0	10,0	82,6	101,6	9,2	MSM46	170.002
2225937	MKTM12100	4,0	12,0	82,6	101,6	10,9	MSM46	170.002
2225936	MKTM1240	4,0	12,0	19,1	38,1	10,9	MSM46	170.002
2225939	MKTM16100	4,0	16,0	82,3	101,6	14,7	MSM46	170.002
2225938	MKTM1640	4,0	16,0	18,8	38,1	14,7	MSM46	170.002

### 12mm & 16mm KM Micro™ Toolholders

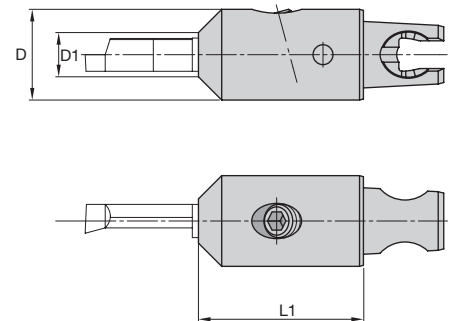

### ■ MKSM

order number	catalog number	D	D1	L1	oval point socket set screw	hex wrench
2253101	KM1612MKSM	16	4	21,59	MSM46	170.002
2253102	KM2016MKSM	20	4	21,59	MSM46	170.002

Boring Inserts

■ MKTB

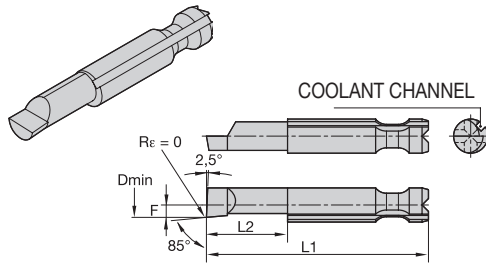

catalog number	D min	L1	L2	F	KC5025
<b>Right hand</b>					
MKTB15804R	1,6	21,3	5,4	0,7	●
MKTB15807R	1,6	24,4	7,9	0,7	●
MKTB23807R	2,4	23,6	7,1	1,0	●
MKTB23812R	2,4	29,2	12,7	1,0	●
MKTB31709R	3,2	26,0	9,5	1,4	●
MKTB31715R	3,2	32,4	15,9	1,4	●
MKTB39612R	4,0	29,2	12,7	1,9	●
MKTB39622R	4,0	38,7	22,2	1,9	●
<b>Left hand</b>					
MKTB15804L	1,6	21,3	5,4	0,7	●
MKTB15807L	1,6	24,4	7,9	0,7	●
MKTB23807L	2,4	23,6	7,1	1,0	●
MKTB23812L	2,4	29,2	12,7	1,0	●
MKTB31709L	3,2	26,0	9,5	1,4	●
MKTB31715L	3,2	32,4	15,9	1,4	●
MKTB39612L	4,0	29,2	12,7	1,9	●
MKTB39622L	4,0	38,7	22,2	1,9	●

Grooving Inserts

■ MKTG

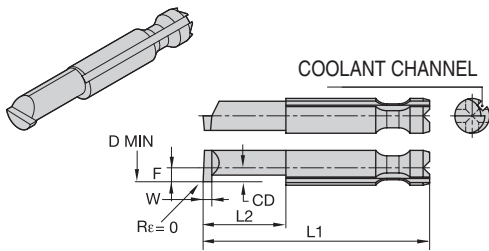

catalog number	D min	W	CD	L1	L2	F	KC5025
<b>Right hand</b>							
MKTG279070076R	2,8	0,8	0,8	24,4	7,9	1,2	●
MKTG356090102R	3,6	1,0	0,9	26,0	9,5	1,5	●
MKTG444120127R	4,4	1,3	1,3	29,2	12,7	1,9	●
<b>Left hand</b>							
MKTG279070076L	2,8	0,8	0,8	24,4	7,9	1,2	●
MKTG356090102L	3,6	1,0	0,9	26,0	9,5	1,5	●
MKTG444120127L	4,4	1,3	1,3	29,2	12,7	1,9	●

Profiling Inserts

■ MKTP

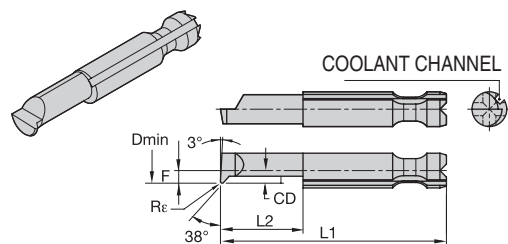

catalog number	D min	CD	L2	L1	F	Re	KC5025
<b>Right hand</b>							
MKTP15804R	1,6	0,4	4,8	21,3	0,7	0,2	●
MKTP23907R	2,4	0,7	7,1	23,6	1,1	0,2	●
MKTP31709R	3,2	1,0	9,5	26,0	1,4	0,2	●
MKTP39612R	4,0	1,3	12,7	29,2	1,9	0,2	●
<b>Left hand</b>							
MKTP15804L	1,6	0,4	4,8	21,3	0,7	0,2	●
MKTP23907L	2,4	0,7	7,1	23,6	1,1	0,2	●
MKTP31709L	3,2	1,0	9,5	26,0	1,4	0,2	●
MKTP39612L	4,0	1,3	12,7	29,2	1,9	0,2	●

### ■ MKTT

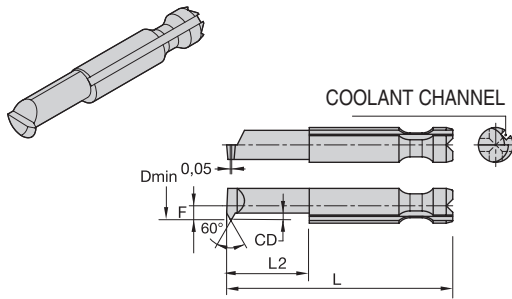

catalog number	D min	CD	L1	L2	F	TPI	Pitch	KC5025
<b>Right hand</b>								
MKTT279070060R	4,4	0,559	24,4	7,9	1,2	32-50	0,5-0,80	●
MKTT356090060R	3,6	0,686	26,0	9,5	1,5	24-50	0,5-1,05	●
MKTT444120060R	2,8	0,813	29,2	12,7	1,9	20-50	0,5-1,27	●
<b>Left hand</b>								
MKTT279070060L	4,4	0,559	24,4	7,9	1,2	32-50	0,5-0,80	●
MKTT356090060L	3,6	0,686	26,0	9,5	1,5	24-50	0,5-1,05	●
MKTT444120060L	2,8	0,813	29,2	12,7	1,9	20-50	0,5-1,27	●

### Insert Blanks

### ■ MKTL

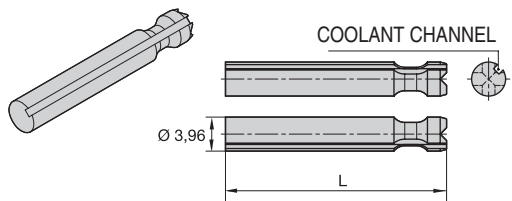

catalog number	L	K1025
<b>Left hand</b>		
MKTL39607	29,5	●
MKTL39612	39,0	●
MKTL39615	24,7	●
MKTL39622	32,6	●

### Metalcutting Safety

(Please read this before using products listed in this catalog.)

Modern metalcutting operations involve high energy, high spindle or cutter speeds, and high temperatures and cutting forces. Hot, flying chips may be projected from the workpiece during metalcutting. Although advanced cutting tool materials are designed and manufactured to withstand the high cutting forces and temperatures that normally occur in these operations, they are susceptible to fragmenting in service, particularly if they are subjected to over-stress or severe impact, or are otherwise abused. Therefore, precautions should be taken to adequately protect workers, observers, and equipment against hot, flying chips, fragmented cutting tools, broken workpieces, or other similar projectiles. Machines should be fully guarded, and personal protective equipment should be used at all times.

When grinding carbide or other advanced cutting tool materials, a suitable means for collection and disposal of dust, mist, or sludge should be provided. Overexposure to dust or mist containing metallic particles can be hazardous to health, particularly if exposure continues over an extended period of time, and may cause eye, skin, and mucous membrane irritation, and temporary or permanent respiratory disease. Certain existing pulmonary and skin conditions may be aggravated by exposure to dust or mist. Adequate ventilation, respiratory protection, and eye protection should be provided when grinding, and workers should avoid breathing of and prolonged skin contact with dust or mist. General Industry Safety and Health Regulations, Part 1910, U.S. Department of Labor, published in Title 29 of the Code of Federal Regulations should be consulted. Obtain from Kennametal and read the applicable Material Safety Data Sheet before grinding.

Cutting tools are only one part of the worker-machine tool system. Many variables exist in machining operations, including: metal removal rate; workpiece size, shape, strength, and rigidity; chucking and fixturing; the load-carrying capability of centers; cutter and spindle speed and torque limitations; the holder and boring bar overhang; available power, and the condition of the tooling and the machine. A safe metalcutting operation must take all of these variables, and others, into consideration.

Kennametal has no control over the end use of its products or the environment into which those products are placed. Kennametal urges that its customers adhere to the recommended standards of use of their metalcutting machines and tools, and that they follow procedures that ensure safe metalcutting operations. The technical information included throughout this catalog, as well as recommendations on machining practices referred to herein, are only advisory in nature and do not constitute representations or warranties and are not necessarily appropriate for any particular work environment or application.

For more information, we suggest you obtain Kennametal's Metalcutting Safety booklet, if you do not already have one. Quantities of safety booklets and Material Safety Data Sheets may be obtained free from the Kennametal Corporate Compliance Office at 724/539-5747, or fax 724-539-5439.

For product safety and environmental inquiries, contact our Corporate Environmental Health and Safety Office at 724/539-5631 or fax 724-539-5372.

Kennametal, the stylized K, Engineering Your Competitive Edge, KENNA PRECISION, KM Micro, and KENBORE are trademarks of Kennametal Inc. The absence of a product, service name, or logo from this list does not constitute a waiver of Kennametal's trademark or other intellectual property rights concerning that name or logo.

Copyright 2007 by Kennametal Inc., Latrobe, PA 15650. All rights reserved.

#### **KENNAMETAL ONLINE**

[www.kennametal.com](http://www.kennametal.com) for:

- online buying
- contract ordering
- order status
- account status
- check price and availability
- favorites list

#### **APPLICATION SUPPORT**

Tech Line

USA and Canada:

**800/835-3668**

Outside USA and Canada:

**724/539-6921**

Monday-Friday: 7am-7pm

Saturday: 9am-3pm

#### **MACHINE UTILIZATION**

Optimize your machine through:

- quick-change tooling
- tool kit assembly
- tool pre-gauging
- advanced cutting tool materials
- tool location management
- tool sensors

#### **KENNAMETAL EDUCATION SERVICES**

To enroll in our unique, five-day application engineering course, call **724/539-6828**.

#### **TOOL MANAGEMENT SYSTEM**

ToolBoss... to reduce your tool-buying, tool-inventory, and tool-supply costs.

Printed in USA  
A07-01 (28) G7



*Engineering Your Competitive Edge*

Kennametal, Inc.  
Metalworking Solutions & Services Group  
1600 Technology Way  
Latrobe, PA 15650

CHANGE SERVICE REQUESTED

Customer Service  
(United States and Canada) Phone

**800/446-7738**

**FAX: 888-505-5050**